



# Installation Instructions

PART NUMBERS: 76022, 84022, CQT76022

## Applications:

Years	Make	Models
2017-Current*	Cadillac	XT5







## Installation Time: 20 min

The time listed above is the average time for professional installers. If you do not feel comfortable performing this installation on your own or are in need of assistance, please contact a professional installer.



Representative Vehicle Photo

## Equipment Required:

 Safety Glasses	 Ratchet	 7 mm 11/16" Sockets	 6" Socket Extension	 Torque Wrench
 Die Grinder				

## DO NOT EXCEED LOWER OF TOWING VEHICLE MANUFACTURER'S RATING OR:

Hitch Type	Max Gross Trailer Weight	Max Tongue Weight
Weight Carrying	4500 lb. (2043 kg)	675 lb. (306 kg)
Weight Distributing	4500 lb. (2043 kg)	675 lb. (306 kg)

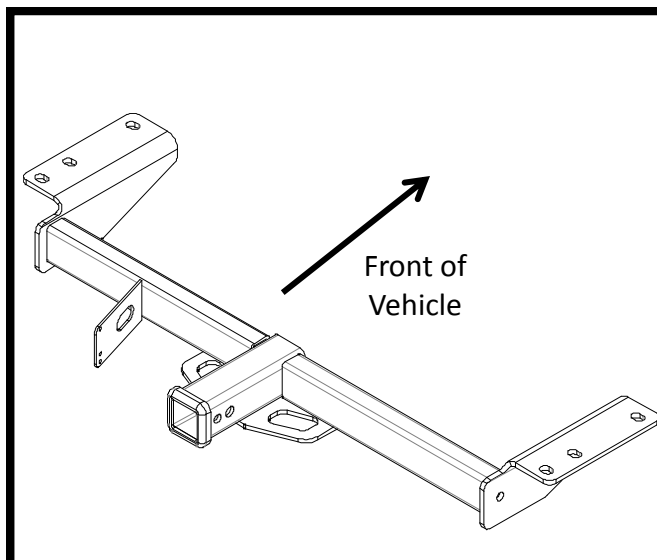

Hitch Illustration







Always wear SAFETY GLASSES when installing hitch

# Installation Instructions

## PART NUMBERS: 76022, 84022, CQT76022

### Fastener Kit: 76022F

①	Qty. (6)	Carriage bolt 1/2" –13 x 1.75, GR5	
②	Qty. (6)	Spacer .250x1.00x2.00	
③	Qty. (6)	Conical washer 1/2"	
④	Qty. (6)	Hex nut 1/2" – 13, GR5	
⑤	Qty. (6)	Pull wire 1/2"	



**Figure 2**



**Figure 3**

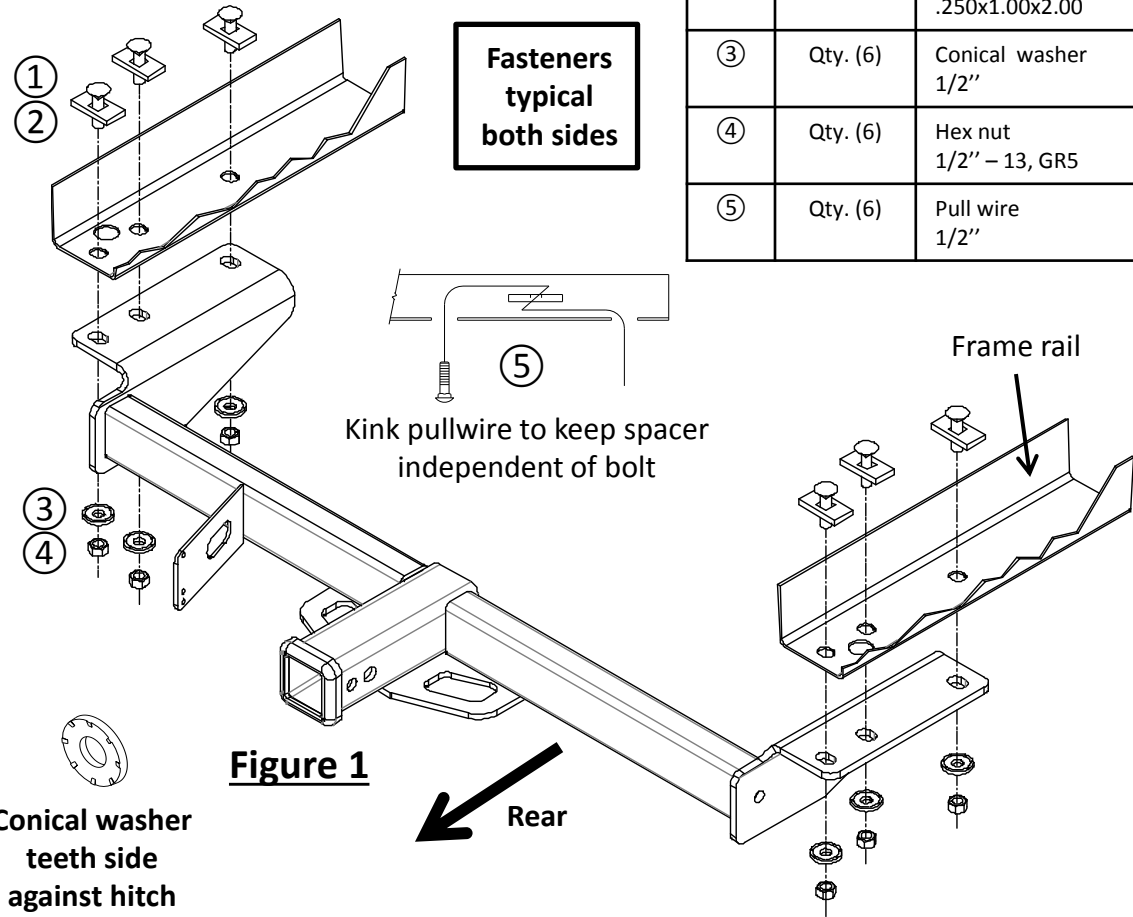

**Figure 1**

Conical washer  
teeth side  
against hitch

- Fascial door removal** – use 7 mm socket to remove (2) bolts from fascia door, see **Figure 2**. Keep the fasteners and door for reinstallation.
- Hitch installation** – insert pull wires ⑤ from the largest round hole of frame rails, see **Figure 3**, and then use them to feed carriage bolts ① and spacer ② into frame rails. Use a die grinder to enlarge the feeding hole if necessary. Leave pull wires attached. Raise the hitch into position and feed carriage bolts through bracket holes, see **Figure 1**. Remove the pull wires and loosely install hex nuts ④ and conical washers ③ to the hitch.
- Tighten all 1/2" fasteners to 75 Lb.-Ft. (102 N\*M)**  **Proper torque is needed to keep the hitch secure to the vehicle when towing.**
- Reinstall the fascia door back when not towing.

Note: check hitch frequently, making sure all fasteners and ball are properly tightened. If hitch is removed, plug all holes in trunk pan or other body panels to prevent entry of water and exhaust fumes. A hitch or ball which has been damaged should be removed and replaced. Observe safety precautions when working beneath a vehicle and wear eye protection. Do not cut access or attachment holes with a torch.

This product complies with safety specifications and requirements for connecting devices and towing systems of the state of New York, V.E.S.C. Regulation V-5 and SAE J684.

**1. Fascia door removal** – use 7 mm socket to remove (2) bolts from fascia door, see **Figure 2**. Keep the fasteners and door for reinstallation.



**2. Hitch installation** – insert pull wires ⑤ from the largest round hole of frame rails, see **Figure 3**, and then use them to feed carriage bolts ① and spacer ② into frame rails. Use a die grinder to enlarge the feeding hole if necessary. Leave pull wires attached. Raise the hitch into position and feed carriage bolts through bracket holes, see **Figure 1**. Remove the pull wires and loosely install hex nuts ④ and conical washers ③ to the hitch.



**3. Tighten all 1/2" fasteners to 75 Lb.-Ft. (102 N\*M)**

**⚠ Proper torque is needed to keep the hitch secure to the vehicle when towing.**

4. Reinstall the fascia door back when not towing.

